

RATES OF APPLICATION USED FOR ESTIMATING QUANTITIES

ITEM	RATE
HOT BITUMINOUS PAVEMENT	110 LBS./SQ. YD./IN.
PLANT MIX BITUMINOUS BASE COURSE	110 LBS./SQ. YD./IN.
COMMERCIAL FERTILIZER (13-13-13)	1,000 LBS./ACRE
AMMONIUM NITRATE	200 LBS./ACRE
AGRICULTURAL LIMESTONE	2.0 TONS/ACRE
VEGETATIVE MATERIALS FOR MULCH	2.0 TONS/ACRE

NOTE: THE AMMONIUM NITRATE IS TO BE APPLIED AFTER GRASS GROWTH IS ESTABLISHED.

NOTE: THICKNESS DIMENSIONS ARE APPROXIMATE. THE TOLERANCES OF THE GOVERNING SPECIFICATIONS WILL CONTROL.

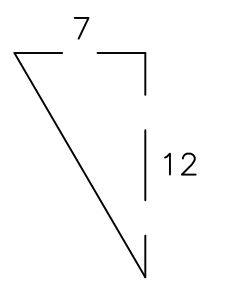

ANGLE OF REPOSE PERMITTED

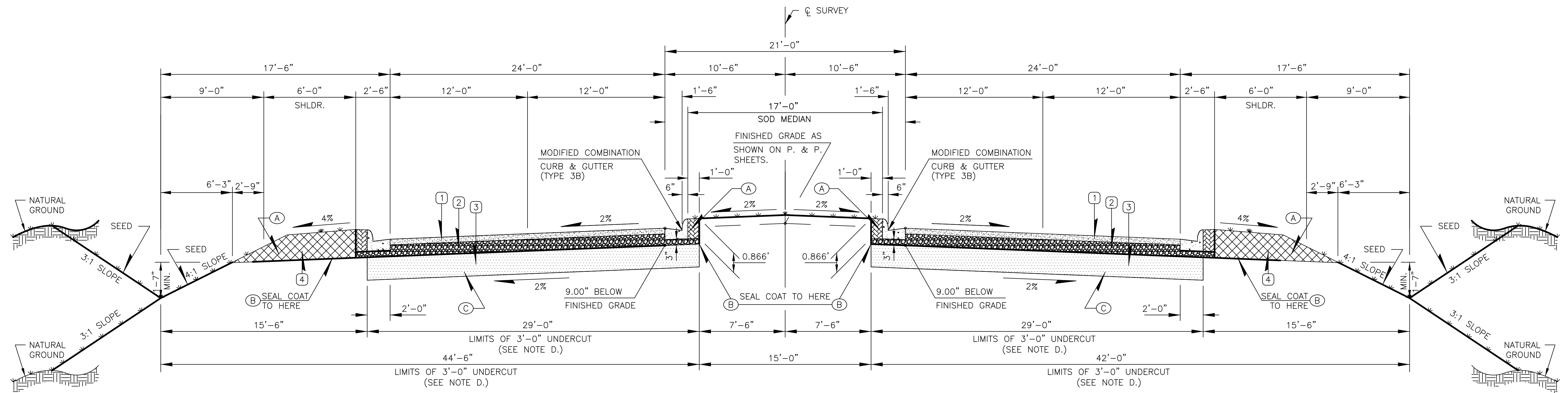

TYPICAL 4 LANE SECTION - HIGHLAND COLONY PARKWAY

HIGHLAND COLONY PARKWAY:

- ① 3 IN HMA, HT (9.5 MM MIXTURE) (1 @ 3 IN.)
- ② 6.00 IN. HMA, HT (19 MM MIXTURE) (2 @ 3 IN.)
- ③ 9.00 IN. STRUCTURE THICKNESS
- ④ 12 IN LIME TREATED SUBGRADE
- ⑤ GRANULAR MATERIAL CLASS (5/C).

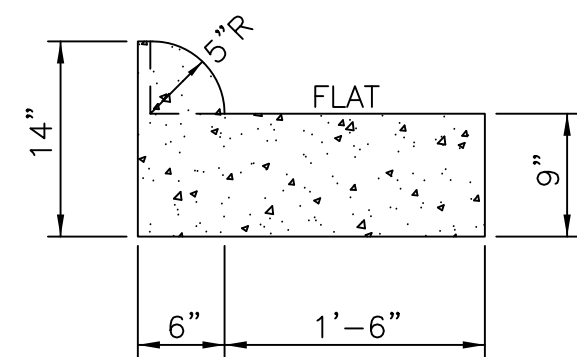

TYPE "3B" MODIFIED COMBINATION CURB & GUTTER



WARNOCK & ASSOCIATES, L.L.C.
ENGINEERING, MANAGEMENT & PLANNING
158 WEST CENTER STREET
CANTON, MS 39046
PH: (601) 855 - 2250

LOCATION:
MADISON CO, MS

LENGTH:
2.33 MILES
NOVEMBER 2014

**HIGHLAND COLONY PARKWAY
RESURFACING &
RECONSTRUCTION**



LOCATION:
MADISON CO, MS

LENGTH:
2.33 MILES
NOVEMBER 2014

WARNOCK &
ASSOCIATES, L.L.C
ENGINEERING, MANAGEMENT &
PLANNING
158 WEST CENTER STREET
CANTON, MS 39046
PH: (601) 855 - 2250

**HIGHLAND COLONY PARKWAY
RESURFACING &
RECONSTRUCTION**

EOP
INTERSECTION OF
HIGHLAND COLONY
PARKWAY AND STATE
MAINTENANCE LIMIT
SOUTH OF MISSISSIPPI
HIGHWAY 463

BOP
HIGHLAND COLONY
PARKWAY INTERSECTION
WITH ENTRANCE TO
WRIGHT & FERGUSON
FUNERAL HOME

